

**DESCRIPTION**

Solenoid valve in line normally open direct acting poppet type.

**CONSTRUCTION**

Body/Armature tube	AISI 303
Plunger and core	AISI 430FR
Springs	AISI 302
Seal material	NBR - FPM - EPDM



**FEATURES**

- Maximum allowable pressure 15bar
- Maximum fluid viscosity 25cSt (mm<sup>2</sup>/s)
- Ambient temperature: from -10°C to +80°C according to the coil
- Universal mounting position

**OPTIONS:** Mounting bracket  
 Versions for use with industrial oxygen  
 c us certified coils

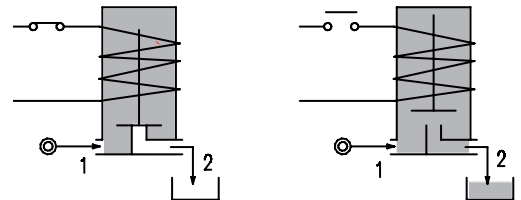
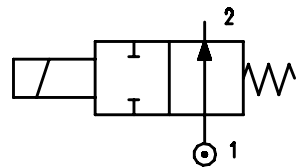

**2**

CONFIGURATIONS			
G1/8"MALE - Push-on for pipes Ø6x4 NW	G1/8"MALE - G1/8"FEMALE NA	G1/8"FEMALE - Push-on for pipes Ø6x4 AW	G1/8"FEMALE - G1/8"FEMALE AA

CODE ① ② ③	Orifice mm	Kv m <sup>3</sup> /h	Differential pressure bar			Electrical data		Coil		Seal ②	Temperature range °C
			Min	Max AC DC		Voltage (V)	Power	Series	Width		
E230... ..15///...	1.5	0.05	0	10	10	All standard voltages	6.5W or 8VA	3	22	NBR=B FPM=V EPDM=E	-10 +90 -10 +140 -10 +140

- ① Configuration      Example: E230NAB15///30B - G1/8" male - G1/8" female connections
- ② Seal                      NBR seal - 24V 50/60Hz 8VA
- ③ Coil

COILS	Alternating Current 50/60Hz (V)							Direct Current (V)			Electrical connection	Connectors
	12	24	48	110	220 230	240	380	12	24	48		
Series 3 Width 22 6.5W or 8VA CODE ③	30A	30B U35B c	30C	30D U35D c	30E	30F U35F c	30G	300 U350 c	301 U351 c	302	DIN 46244	PG9 CODE 10348000

**DESCRIPTION**  
 Class F insulation  
 Voltage tolerance  
 AC +15% -10%  
 DC ± 10%  
 Protection class  
 IP65 with connector fitted  
 IP00 without connector  
 Continuous service ED100%

**OPTIONS**  
 Class H insulation  
 Cable attached  
 Special coil voltage  
 Special coil powers  
 c certified coils

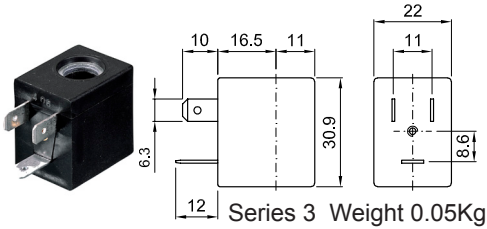

Series 3 Weight 0.05Kg

(for more details see section 8)

### SPARE PARTS LIST

1. OR
2. Coil

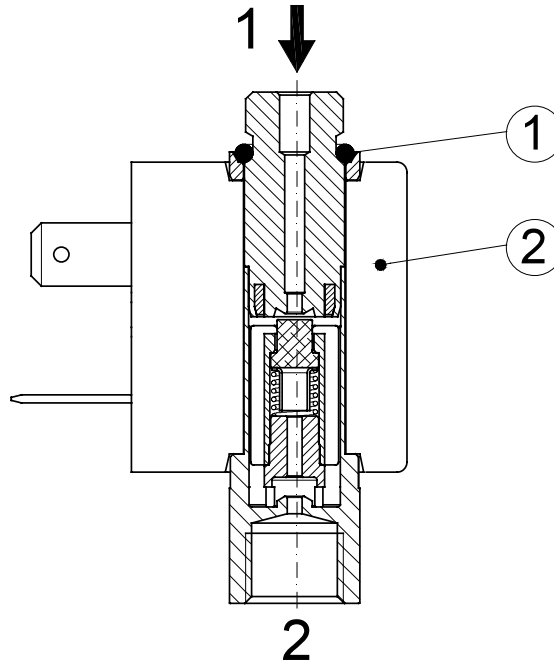

### OVERALL DIMENSIONS

