

**DESCRIPTION**

Solenoid valve 2 way normally closed with servo-assisted diaphragm

**CONSTRUCTION**

Body and cover	Brass
Armature tube	Stainless steel
Plunger and core	Stainless steel
Springs	Stainless steel
Seal material	NBR FPM EPDM



**FEATURES**

- Minimum differential pressure 0.15 bar
- Maximum allowable pressure\* 25 bar
- Maximum fluid viscosity 25cSt (mm<sup>2</sup>/s)
- Ambient temperature: with class F coil -10°C +55°C  
with class H coil -10°C +80°C
- Preferred mounting position with vertical coil above

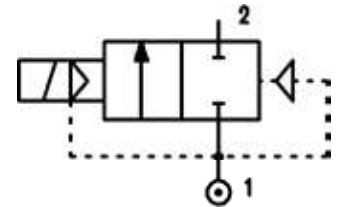

4

- OPTIONS:**
- Manual override
  - Electroless nickel plating
  - Series 7 explosion proof coil according to ATEX - EExmII
  - Version with slow closing diaphragm
  - Version for vacuum applications (air/gas)

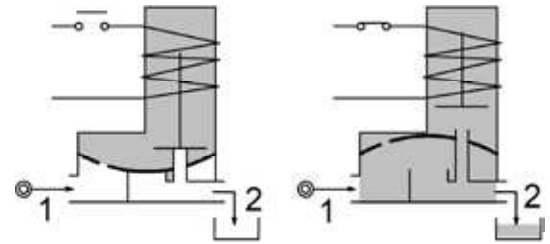

Certified versions:



CODE ① ②	Connection G ISO 228	Orifice mm	Kv m <sup>3</sup> /h	Differential pressure bar			Nominal power			Coil		Seal ①	Temp. range °C
				Min	Max AC DC		AC Inrush	VA Holding	DC Watt	Series	Width		
E107B...10///...	1/4"	10	1.5	0.15	15	15	12	8	6.5	3	22	NBR=B	-10 +90
E107C...10///...	3/8"	10	1.7	0.15	15	15							
E107C...12///...	3/8"	12	2.2	0.15	15	15							
E107D...12///...	1/2"	12	2.5	0.15	15	15							
E107E...18///...	3/4"	18	5.5	0.15	13	13							
E107F...25///...	1"	25	10.2	0.15	10	10							
E107G...30///...	1" 1/4	30	15	0.15	10	10	15	11	5	4	30	FPM=V	-10 +130
③E107C...12/W/...	3/8"	12	2.2	0.5	25	25							
③E107D...12/W/...	1/2"	12	2.5	0.5	25	25							

- ① Seal
- ② Coil
- ③ Reinforced diaphragm

Example: E107DB12///301 NBR seal  
Coil 24V DC

COILS	Alternating Current 50/60Hz Volt							Direct Current Volt			Electrical connection	Connectors
	12	24	48	110	220 230	240	380	12	24	48		
Series 3 Width 22 Code ②	30A	30B	30C	30D	30E	30F	30G	300	301	302	DIN 46244	PG9 code 10348000
Series 4 Width 30 Code ②	40A	40B	40C	40D	40E	40F	40G	400	401	402	DIN 43650A	PG9 code 10349000

**DESCRIPTION**  
 Class F insulation  
 Voltage tolerance  
 AC +15% -10%  
 DC ± 10%  
 Protection class  
 IP65 with connector fitted  
 IP00 without connector  
 Continuous service ED100%

**OPTIONS**  
 Class H insulation  
 Cable attached  
 Special coil voltage  
 Special coil powers

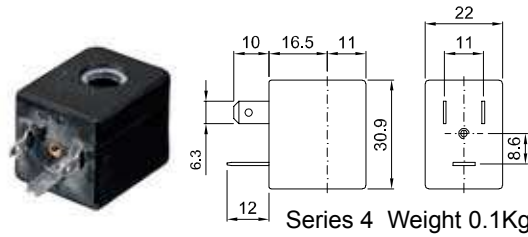
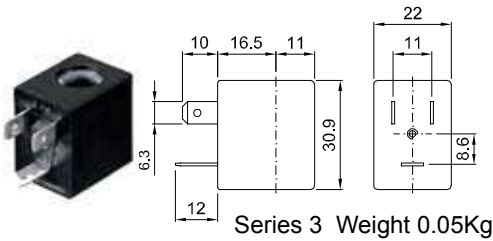

### SPARE PARTS LIST

1. Coil fixing nut
2. Coil
3. Plunger
4. Armature tube with core
5. Diaphragm assembly

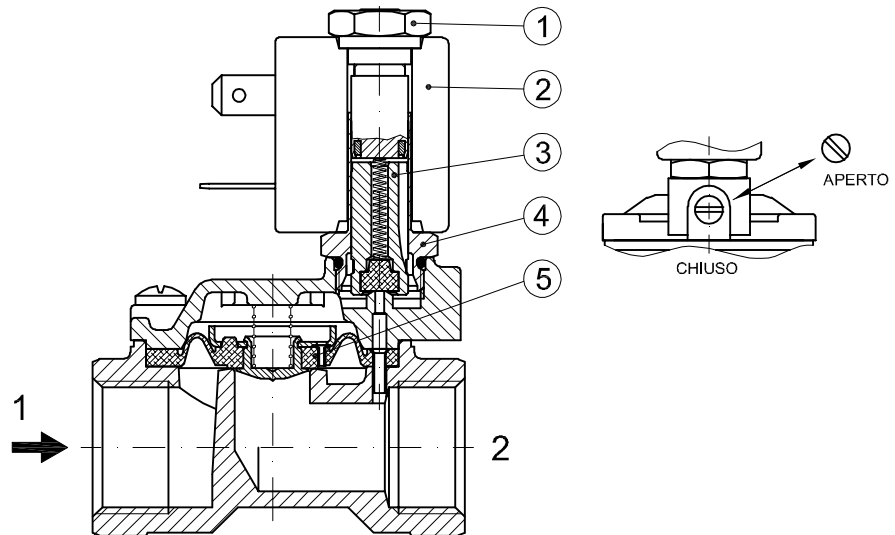

### OVERALL DIMENSION

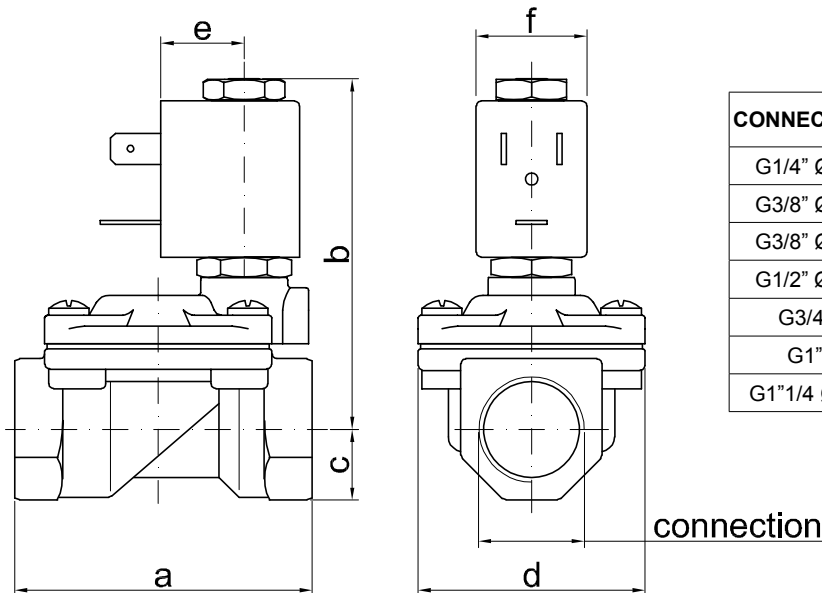

CONNECTION	a	b	c	d	e	f	weight Kg
G1/4" Ø10	49	65	11	32	16	22	0.23
G3/8" Ø10	49	65	11	32	16	22	0.24
G3/8" Ø12	59	70	14	45	16	22	0.42
G1/2" Ø12	59	70	14	45	16	22	0.39
G3/4"	79	76	18	55	16	22	0.65
G1"	96	85	20	72	16	22	1.05
G1 1/4" Ø30	119	92	25	85	16	22	1.70

**DESCRIPTION**

Solenoid valve 2 way normally closed with servo-assisted diaphragm

**CONSTRUCTION**

Body and cover	Brass
Armature tube	Stainless steel
Plunger and core	Stainless steel
Springs	Stainless steel
Seal material	NBR FPM EPDM



**FEATURES**

- Minimum differential pressure 0.15÷3 bar
- Maximum allowable pressure\* 20 bar
- Maximum fluid viscosity 25cSt (mm<sup>2</sup>/s)
- Ambient temperature: with class F coil -10°C +55°C  
with class H coil -10°C +80°C
- Preferred mounting position with vertical coil above

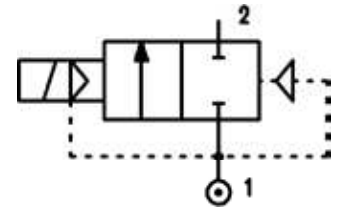

**4**

- OPTIONS:** Manual override  
Electroless nickel plating  
Version for vacuum applications (air/gas)

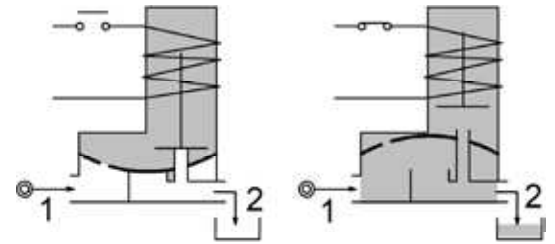

CODE ① ②	Connection G ISO 228	Orifice mm	Kv m <sup>3</sup> /h	Differential pressure bar			Nominal power			Coil		Seal ①	Temp. range °C
				Min	Max		AC Inrush	VA Holding	DC Watt	Series	Width		
E107G...37///...	1"1/4	37	18	0.15	10	10	20	15	10	2	30	NBR=B EPDM=E FPM=V	-10 +90 -10 +140 -10 +130
E107H...37///...	1"1/2	37	21	0.15	10	10							
E107I...50///...	2"	50	36	0.15	10	10							
E107MB75///...	2"1/2	75	75	0.3	5	5	20	15	10	2	30	NBR=B	-10 +90
E107RB75///...	3"	75	84	0.3	5	5							
③E107MB75/W/...	2"1/2	75	75	3	15	15							
③E107RB75/W/...	3"	75	84	3	15	15							

- ① Seal
  - ② Coil
  - ③ Reinforced diaphragm
- Example: E107IB50///201 NBR seal  
Coil 24V DC

\* REMARK: The maximum allowable pressure PS for steam 2,5bar (gauge pressure)

COILS	Alternating Current 50/60Hz Volt							Direct Current Volt			Electrical connection	Connectors
	12	24	48	110	220 230	240	380	12	24	48		
Series 2 Width 30 Code ②	20A	20B	20C	20D	20E	20F	20G	200	201	202	DIN 43650A	PG9 code 10349000

**DESCRIPTION**  
 Class F insulation  
 Voltage tolerance  
 AC +15% -10%  
 DC ± 10%  
 Protection class  
 IP65 with connector fitted  
 IP00 without connector  
 Continuous service ED100%

**OPTIONS**  
 Class H insulation  
 Cable attached  
 Special coil voltage  
 Special coil powers

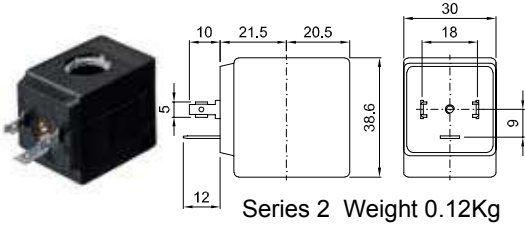

### SPARE PARTS LIST

1. Coil fixing nut
2. Coil
3. Plunger
4. Armature tube with core
5. Diaphragm assembly
6. Speed control valve
7. Water hammering reducer  
 $\varnothing 0.8-\varnothing 1-\varnothing 1.2$

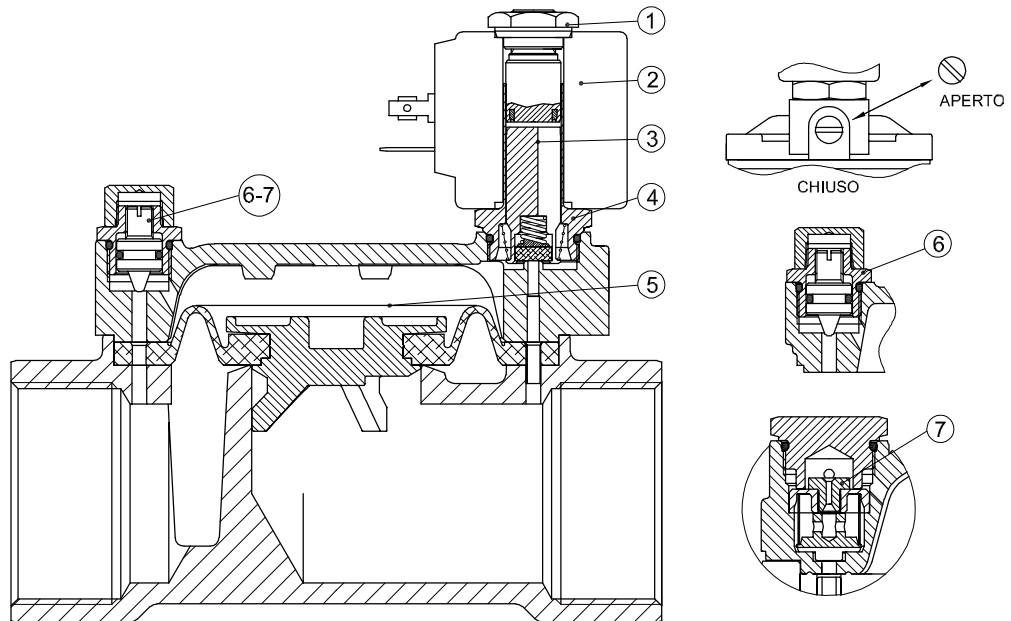

### OVERALL DIMENSION

