

DESCRIPTION

Solenoid valve 2 way normally closed
 direct acting with dry armature.
 No metal parts in contact with the media.

CONSTRUCTION

Body	Acetal copolymer
Armature tube	AISI 303
Plunger and core	AISI 430FR
Springs	AISI 302
Seal material	SILICONE - FPM



2

FEATURES

Maximum allowable pressure PS 2bar
 Maximum fluid viscosity 25cSt (mm²/s)
 Ambient temperature: from -10°C to +80°C according to the coil
 Mounting position with vertical coil above

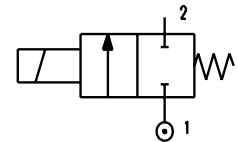

OPTIONS: US certified coils

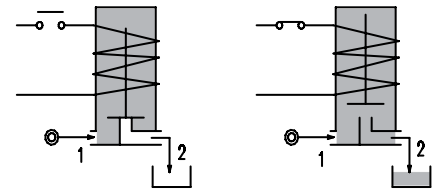

CODE ① ②	Connection	Orifice mm	Kv m ³ /h	Differential pressure bar			Nominal power			Coil		Seal ①	Temp. range °C
				Min	Max		AC Inrush	VA Holding	DC Watt	Series	Width		
					AC	DC							
E161P...8///...	Hosetail DN8	8	1.1	0	0.15	0.15	20	15	10	2	30	SILICONE=S FPM=V	<+95°C
E161P...8/1/...	Hosetail DN8	8	1.1	0	0.5	0.5	40	30	27	5	36		

For use with VACUUM - feeds from 2 to 1

CODE ① ②	Connection	Orifice mm	Kv m ³ /h	Differential pressure bar			Nominal power			Coil		Seal ①	Temp. range °C
				Min	Max		AC Inrush	VA Holding	DC Watt	Series	Width		
					AC	DC							
E161P...8/V/...	Hosetail DN8	8	1.1	0	-0.9	-0.7	20	15	10	2	30	SILICONE=S FPM=V	<+95°C
E161P...8/V/...	Hosetail DN8	8	1.1	0	-0.9	-0.9	40	30	27	5	36		

- ① Seal
- ② Coil

Example: E161PS8///20E - Coil 230V 50/60Hz

COILS ②	Alternating Current 50/60Hz (V)							Direct Current (V)			Electrical connection	Connectors
	12	24	48	110	220 230	240	380	12	24	48		
Series 2 Width 30	20A	20B	20C	20D	20E	20F	20G	200	201	202	DIN 43650A	PG9 code 10349000
Series 5 Width 36	52A	52B	52C	52D	52E	52F	52G	520	521	522	DIN 43650A	PG11 code 10349001

DESCRIPTION
 Insulation class
 Series 2 =F Series 5=H
 Voltage tolerance
 AC +15% -10%
 DC ± 10%
 Protection class
 IP65 with connector fitted
 IP00 without connector

OPTIONS
 Class H insulation (series 2)
 Cable attached
 Special coil voltage
 Special coil powers
 US certified coils

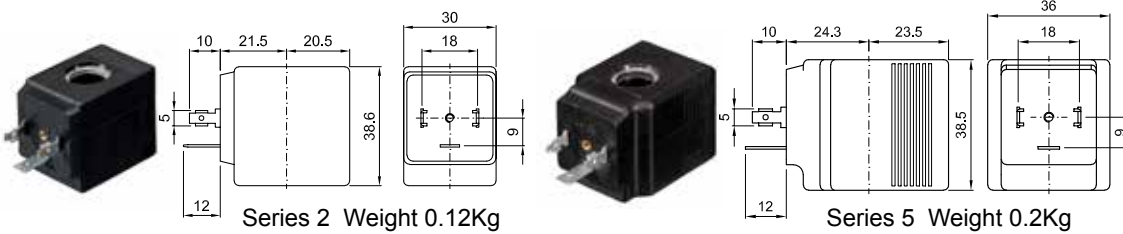

(for coil details see section 8)

SPARE PARTS LIST

1. Coil fixing nut
2. Coil
3. Diaphragm

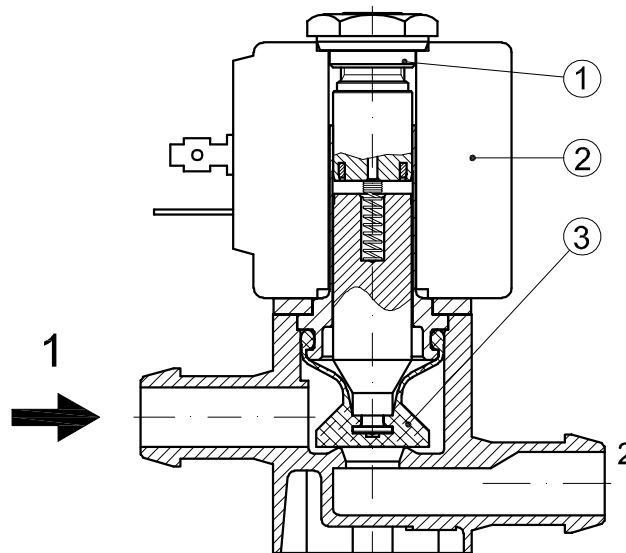

OVERALL DIMENSION

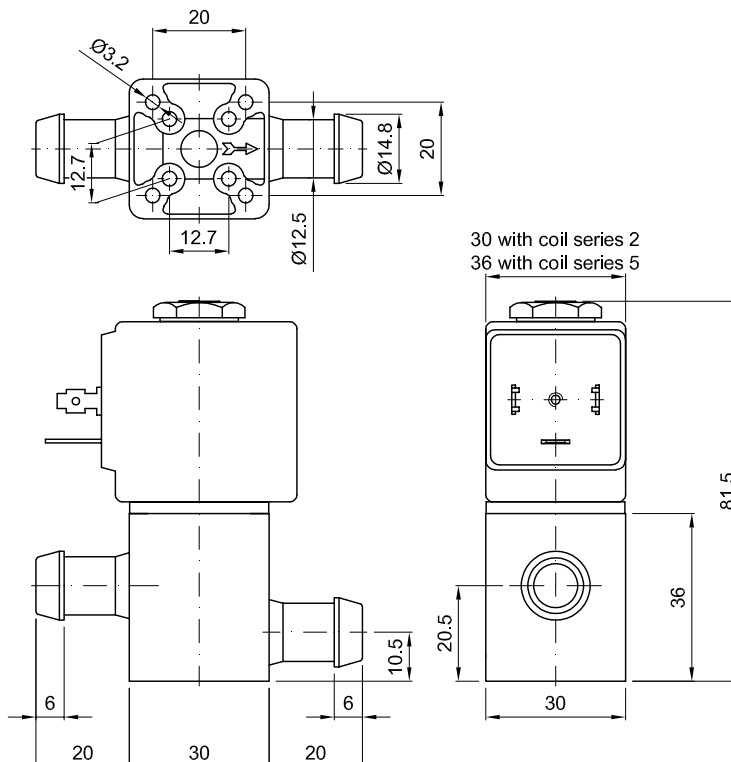

Weight with coil series 2=0.23Kg
 Weight with coil series 5=0.31Kg