

**DESCRIPTION**

Solenoid valve 2 way normally closed with servo-assisted piston suitable for air and water.  
Its requested a minimum differential pressure of 3 bar.



**CONSTRUCTION**

Body and cover	Brass
Armature tube	Stainless steel
Plunger and core	Stainless steel
Piston	PBT
Springs	Stainless steel
Seal material	main seal PTFE other FPM

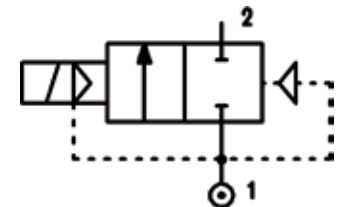

**4**

**FEATURES**

Minimum differential pressure 3 bar  
 Maximum allowable pressure 100 bar  
 Maximum fluid viscosity 12cSt (mm<sup>2</sup>/s)  
 Ambient temperature: with class F coil -10°C +55°C  
 with class H coil -10°C +80°C  
 Preferred mounting position with vertical coil above

**OPTIONS:** Electroless nickel plating  
 c us certified coils

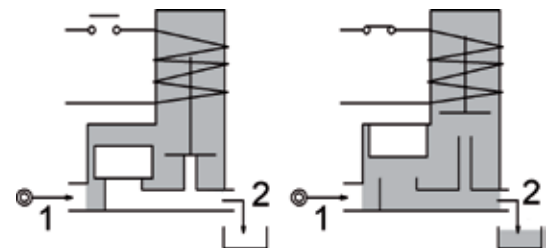

CODE ②	Connection G ISO 228	Orifice mm	Kv l/min	Differential pressure bar			Nominal power			Coil		Seal	Temperature range °C
				Min	Max		AC Inrush	VA Holding	DC Watt	Series	Width		
					AC	DC							
E124DW12///...	1/2"	12	60	3	100	100	20	15	10	2	30	PTFE=W	-10 +95

② Coil Example: E124DW12///20E PTFE seal  
 Coil 220-230V 50-60Hz

COILS	Alternating Current 50/60Hz Volt							Direct Current Volt			Electrical connection	Connectors
	12	24	48	110	220 230	240	380	12	24	48		
Series 2 Width 30 Code ②	20A	20B	20C	20D	20E	20F	20G	200	201	202	DIN 43650A	PG9 code 10349000

**DESCRIPTION**  
 Class F insulation  
 Voltage tolerance  
 AC +15% -10%  
 DC ± 10%  
 Protection class  
 IP65 with connector fitted  
 IP00 without connector  
 Continuous service ED100%

**OPTIONS**  
 Class H insulation  
 Cable attached  
 Special coil voltage  
 Special coil powers  
 c US certified coils

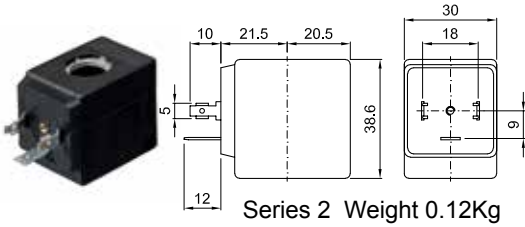

**SPARE PARTS LIST**

1. Coil fixing nut
2. Coil
3. Armature tube assembly
4. Plunger assembly
5. Piston assembly
6. OR
7. OR

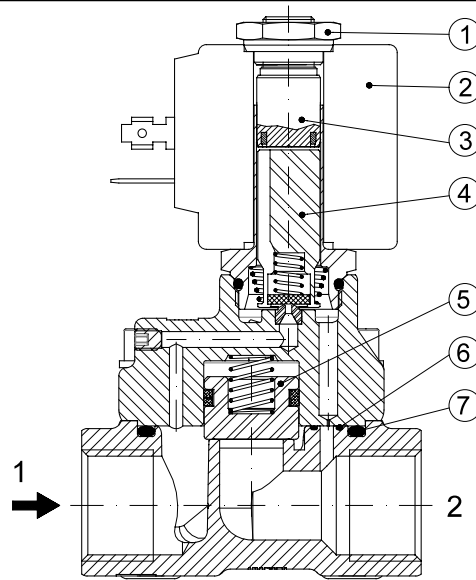

**OVERALL DIMENSION**

