

DESCRIPTION

Solenoid valve 2 way normally open
direct acting poppet type

CONSTRUCTION

Body	Brass
Armature tube	Brass
Plunger and core	Stainless steel
Springs	Stainless steel
Seal material	NBR
	FPM
	EPDM



2

FEATURES

Maximum allowable pressure 50bar*
 Maximum fluid viscosity 25cSt (mm²/s)
 Ambient temperature: with class F coil -10°C +55°C
 with class H coil -10°C +80°C
 Universal mounting position

OPTIONS: Stainless steel armature tube
 Electroless nickel plating

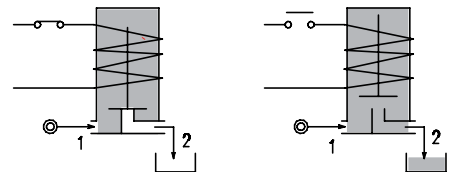
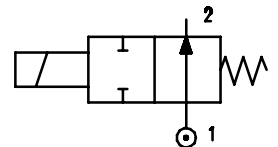

CODE ① ②	Connection G ISO 228	Orifice mm	Kv m ³ /h	Differential pressure bar			Nominal power			Coil		Seal ①	Temp. range °C
				Min	Max		AC Inrush	VA Holding	DC Watt	Series	Width		
					AC	DC							
E206A...15///...	1/8"	1.5	0.07	0	23	-	20	15	-	2	30	NBR=B	-10 +90
E206A...20///...		2	0.1	0	17	-							
E206A...25///...		2.5	0.15	0	12	-							
E206A...35///...		3.5	0.32	0	7	-							
E206A...15///...	1/8"	1.5	0.07	0	23	23	40	30	27	5	36	EPDM=E	-10 +140
E206A...20///...		2	0.1	0	17	17							
E206A...25///...		2.5	0.15	0	12	12							
E206A...35///...		3.5	0.32	0	7	7							
D206A...15/3/...	1/8"	1.5	0.07	0	-	18	-	-	10	2	30	FPM=V	-10 +130
D206A...20/3/...		2	0.1	0	-	11							
D206A...25/3/...		2.5	0.15	0	-	7							
D206A...35/3/...		3.5	0.32	0	-	4							

① Seal Example: E206BB20///20E NBR seal
 ② Coil Coil 230V 50/60Hz

* REMARK: The maximum allowable pressure PS for steam is 2,5bar (gauge pressure)

COILS	Alternating Current 50/60Hz Volt							Direct Current Volt			Electrical connection	Connectors
	12	24	48	110	220 230	240	380	12	24	48		
Series 2 Width 30 Code ②	20A	20B	20C	20D	20E	20F	20G	200	201	202	DIN 43650A	PG9 code 10349000
Series 5 Width 36 Code ②	52A	52B	52C	52D	52E	52F	52G	520	521	522	DIN 43650A	PG11 code 10349001

DESCRIPTION
 Insulation class
 Series 2 =F Series 5=H
 Voltage tolerance
 AC +15% -10%
 DC ± 10%
 Protection class
 IP65 with connector fitted
 IP00 without connector
 Continuous service ED100%

OPTIONS
 Class H insulation (series 2)
 Cable attached
 Special coil voltage
 Special coil powers

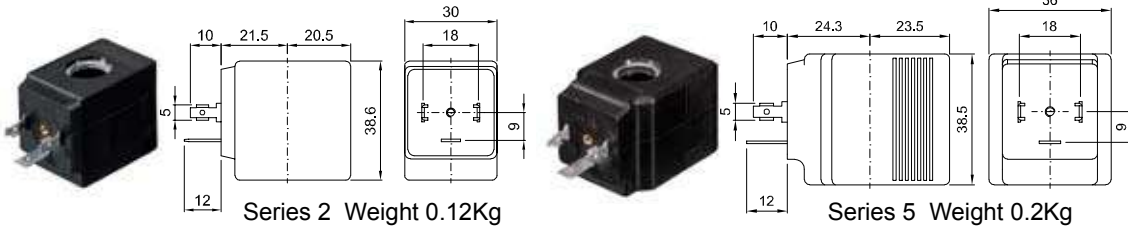

SPARE PARTS LIST

1. Coil fixing nut
2. Coil
3. Seal assembly
4. Armature tube with core

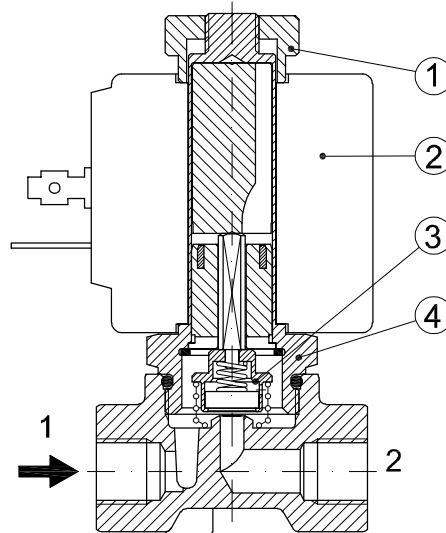

OVERALL DIMENSION

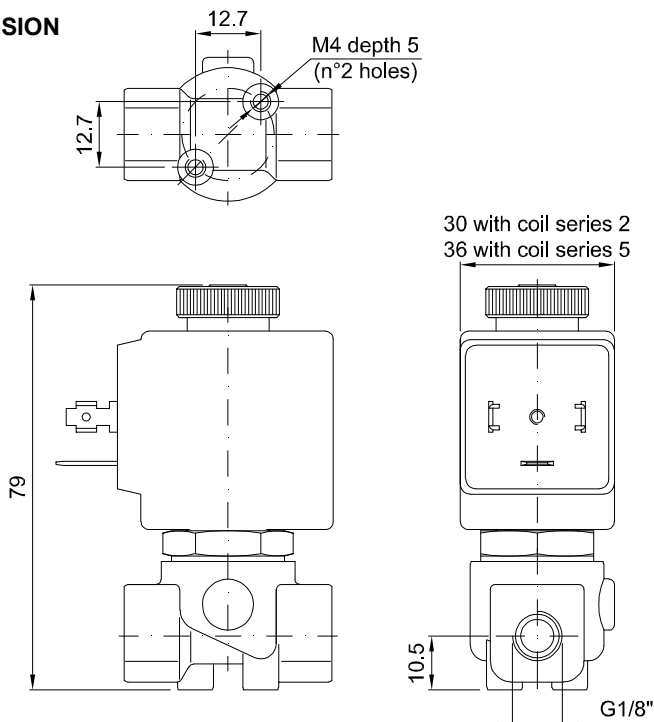

Weight with coil series 2=0.30Kg
 Weight with coil series 5=0.38Kg

DESCRIPTION

Solenoid valve 2 way normally open
direct acting poppet type

CONSTRUCTION

Body	Brass
Armature tube	Brass
Plunger and core	Stainless steel
Springs	Stainless steel
Seal material	NBR FPM EPDM



2

FEATURES

Maximum allowable pressure 50bar*
 Maximum fluid viscosity 25cSt (mm²/s)
 Ambient temperature: with class F coil -10°C +55°C
 with class H coil -10°C +80°C
 Universal mounting position

OPTIONS: Stainless steel armature tube
 Electroless nickel plating

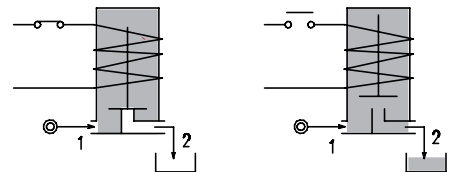
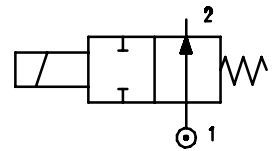

CODE ① ②	Connection G ISO 228	Orifice mm	Kv m ³ /h	Differential pressure bar			Nominal power			Coil		Seal ①	Temp. range °C	
				Min	Max		AC Inrush	VA Holding	DC Watt	Series	Width			
					AC	DC								
E206B...15///...	1/4"	1.5	0.07	0	23	-	20	15	-	2	30	NBR=B EPDM=E FPM=V	-10 +90	
E206B...20///...		2	0.1	0	17	-								
E206B...25///...		2.5	0.15	0	12	-								
E206B...35///...		3.5	0.32	0	7	-								
E206B...45///...		4.5	0.41	0	4.5	-								
E206B...52///...		5.2	0.47	0	3	-								
E206B...15///...	1/4"	1.5	0.07	0	23	23	40	30	27	5	36			-10 +140
E206B...20///...		2	0.1	0	17	17								
E206B...25///...		2.5	0.15	0	12	12								
E206B...35///...		3.5	0.32	0	7	7								
E206B...45///...		4.5	0.41	0	4.5	4.5								
E206B...52///...		5.2	0.47	0	3	3								
E206B...64///...	6.4	0.64	0	3.5	3.5									
D206B...15/3/...	1/4"	1.5	0.07	0	-	18	-	-	10	2	30	-10 +130		
D206B...20/3/...		2	0.1	0	-	11								
D206B...25/3/...		2.5	0.15	0	-	7								
D206B...35/3/...		3.5	0.32	0	-	4								
D206B...45/3/...		4.5	0.41	0	-	3								
D206B...52/3/...		5.2	0.47	0	-	2.2								

① Seal Example: E206BB35///20E NBR seal
 ② Coil Coil 230V 50/60Hz

* REMARK: The maximum allowable pressure PS for steam is 2,5bar (gauge pressure)

COILS	Alternating Current 50/60Hz Volt							Direct Current Volt			Electrical connection	Connectors
	12	24	48	110	220 230	240	380	12	24	48		
Series 2 Width 30 Code ②	20A	20B	20C	20D	20E	20F	20G	200	201	202	DIN 43650A	PG9 code 10349000
Series 5 Width 36 Code ②	52A	52B	52C	52D	52E	52F	52G	520	521	522	DIN 43650A	PG11 code 10349001

DESCRIPTION
 Insulation class
 Series 2 =F Series 5=H
 Voltage tolerance
 AC +15% -10%
 DC ± 10%
 Protection class
 IP65 with connector fitted
 IP00 without connector
 Continuous service ED100%

OPTIONS
 Class H insulation (series 2)
 Cable attached
 Special coil voltage
 Special coil powers

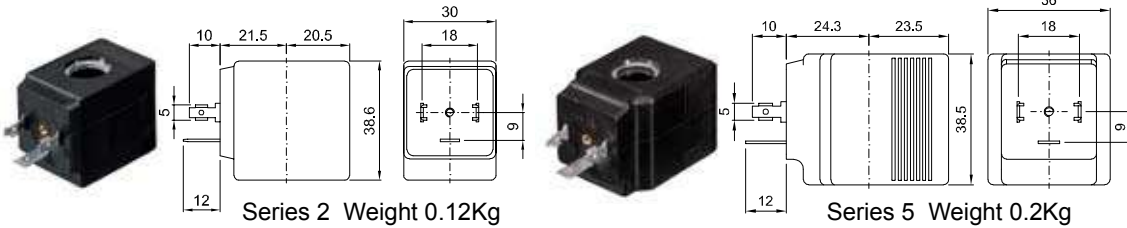

SPARE PARTS LIST

1. Coil fixing nut
2. Coil
3. Seal assembly
4. Armature tube with core

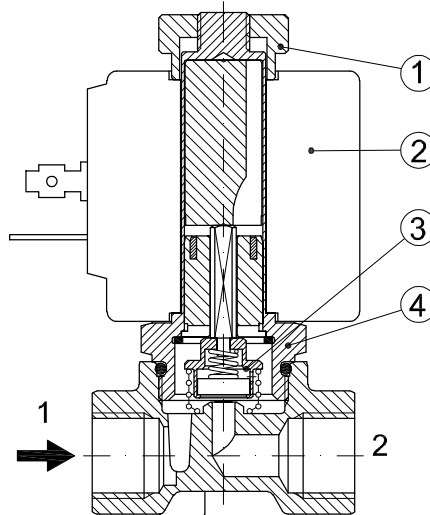

OVERALL DIMENSION

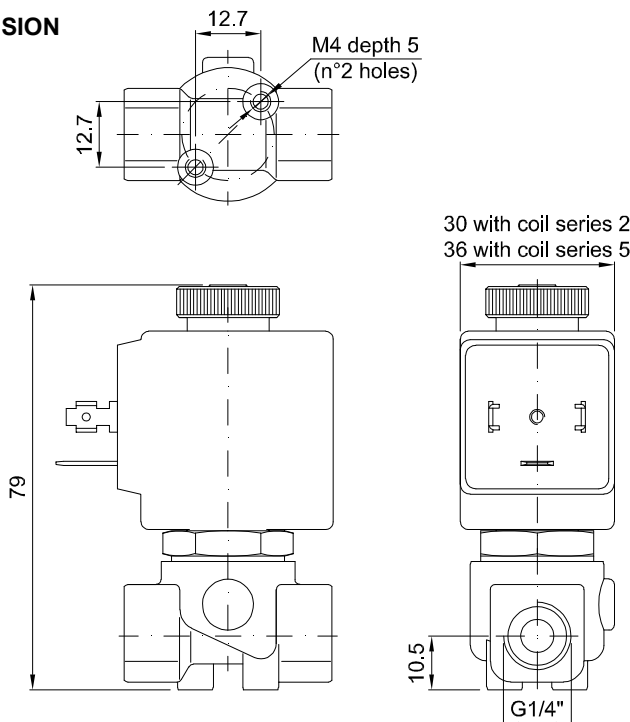

Weight with coil series 2=0.30Kg
 Weight with coil series 5=0.38Kg

COILS	Alternating Current 50/60Hz Volt							Direct Current Volt			Electrical connection	Connectors
	12	24	48	110	220 230	240	380	12	24	48		
Series 2 Width 30 Code ②	20A	20B	20C	20D	20E	20F	20G	200	201	202	DIN 43650A	PG9 code 10349000
Series 5 Width 36 Code ②	52A	52B	52C	52D	52E	52F	52G	520	521	522	DIN 43650A	PG11 code 10349001

DESCRIPTION
 Insulation class
 Series 2 =F Series 5=H
 Voltage tolerance
 AC +15% -10%
 DC ± 10%
 Protection class
 IP65 with connector fitted
 IP00 without connector
 Continuous service ED100%

OPTIONS
 Class H insulation (series 2)
 Cable attached
 Special coil voltage
 Special coil powers

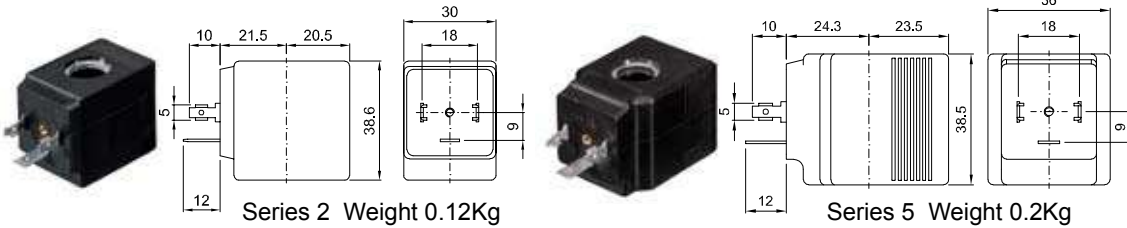

SPARE PARTS LIST

1. Coil fixing nut
2. Coil
3. Seal assembly
4. Armature tube with core

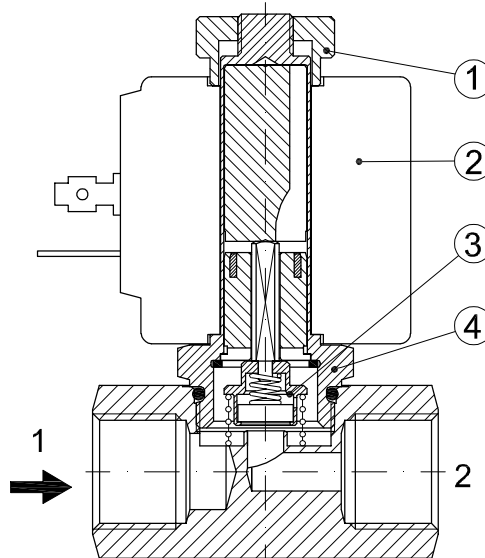

OVERALL DIMENSION

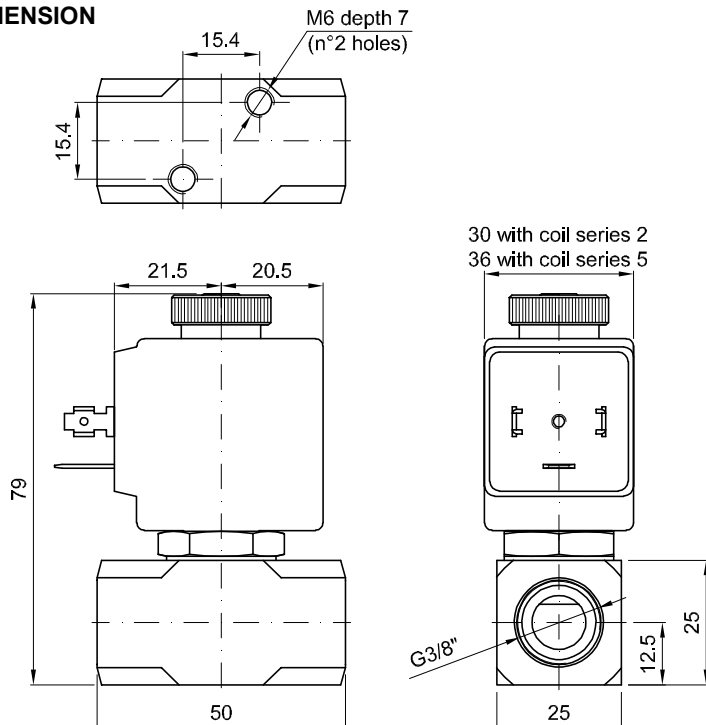

Weight with coil series 2=0.30Kg
 Weight with coil series 5=0.38Kg

COILS	Alternating Current 50/60Hz Volt							Direct Current Volt			Electrical connection	Connectors
	12	24	48	110	220 230	240	380	12	24	48		
Series 2 Width 30 Code ②	20A	20B	20C	20D	20E	20F	20G	200	201	202	DIN 43650A	PG9 code 10349000
Series 5 Width 36 Code ②	52A	52B	52C	52D	52E	52F	52G	520	521	522	DIN 43650A	PG11 code 10349001

DESCRIPTION
 Insulation class
 Series 2 =F Series 5=H
 Voltage tolerance
 AC +15% -10%
 DC ± 10%
 Protection class
 IP65 with connector fitted
 IP00 without connector
 Continuous service ED100%

OPTIONS
 Class H insulation (series 2)
 Cable attached
 Special coil voltage
 Special coil powers

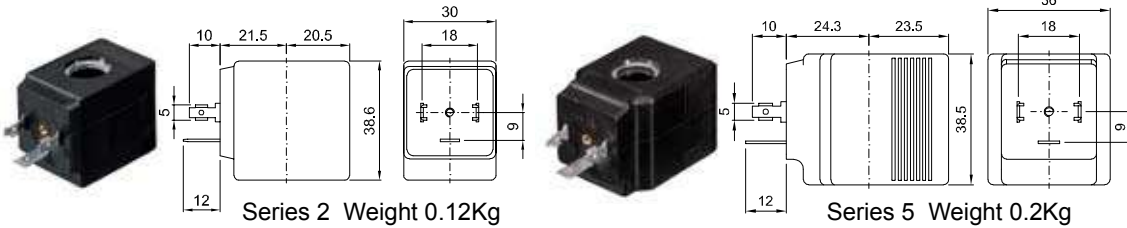

SPARE PARTS LIST

1. Coil fixing nut
2. Coil
3. Seal assembly
4. Armature tube with core

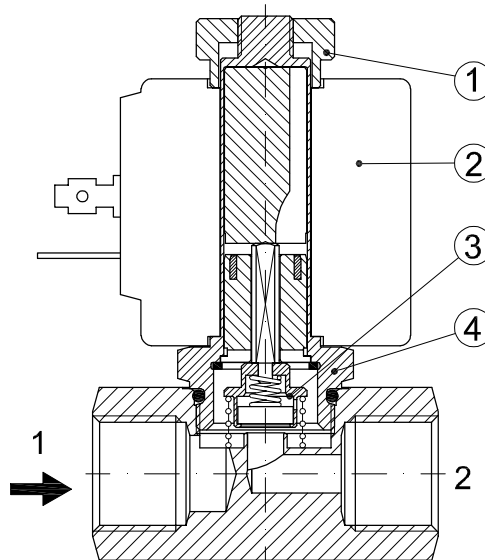

OVERALL DIMENSION

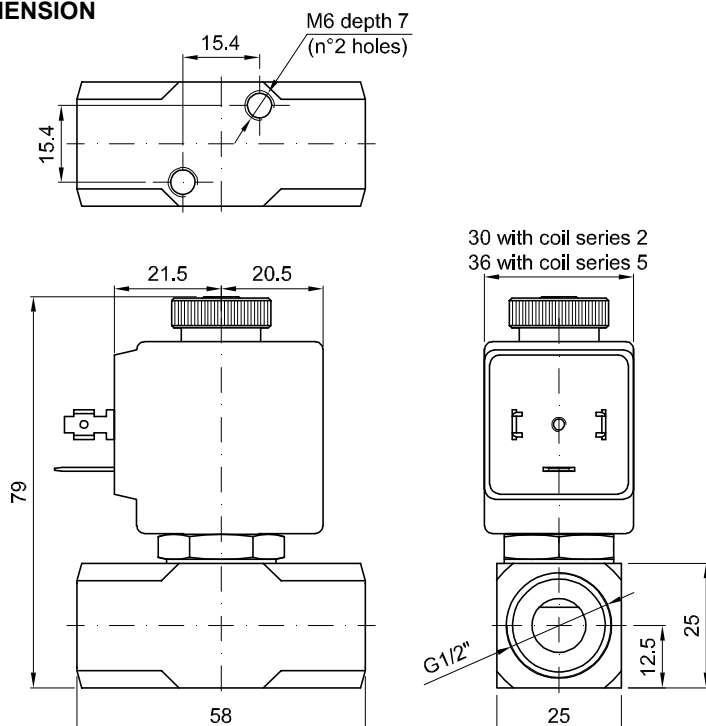

Weight with coil series 2=0.30Kg
 Weight with coil series 5=0.38Kg