

COIL	Alternating current ~50 /60Hz Volt							Direct Current Volt			Electrical connection	Connector
	12	24	48	110	220 230	240	380	12	24	48		
Type 2 Width 30 Code ②	20A	20B	20C	20D	20E	20F	20G	200	201	202	DIN 43650A	PG9 code 10349000

DESCRIPTION
 Class F insulation
 Voltage tolerance
 AC +15% -10%
 DC ±10%
 Protection to IP65
 with connector fitted
 Continuous service
 ED100%

OPTIONS
 Class H insulation
 Cable attached
 Special coil voltage
 Special coil powers

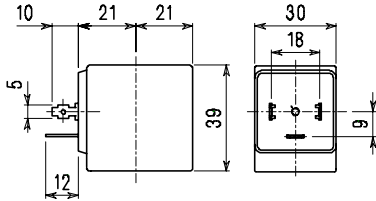
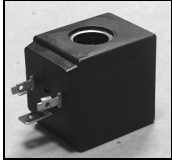

Type 2 Weight 0.12Kg

SPARE PARTS LIST

- 1.Coil fixing nut
- 2.Coil
- 3.Armature assembly
- 4.Armature tube with core

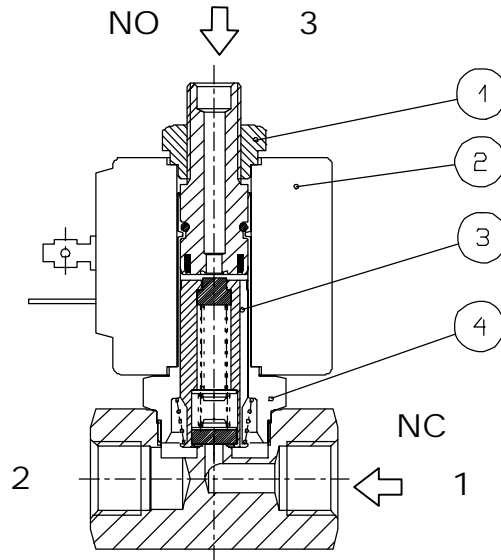

OVERALL DIMENSION

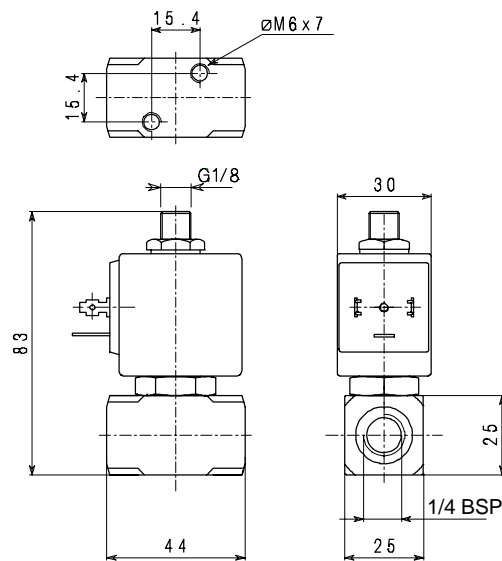

Weight 0.36 Kg