

**DESCRIPTION**

Solenoid valve 2 way normally closed with servo-assisted diaphragm

**CONSTRUCTION**

Body and cover	Brass
Armature tube	Stainless steel
Plunger and core	Stainless steel
Springs	Stainless steel
Seal material	NBR
	FPM
	EPDM



**FEATURES**

- Minimum differential pressure 0.15 bar
- Maximum allowable pressure\* : 25 bar (up to G1"1/2)  
20 bar (over G1"1/2)
- Maximum fluid viscosity 25cSt (mm<sup>2</sup>/s)
- Ambient temperature : with class F coil -10°C +55°C  
with class H coil -10°C +80°C
- Preferred mounting position with vertical coil above

**OPTIONS :**

- Manual override
- Electroless nickel plating
- Explosion proof coil according to ATEX - EExmII Series 7 (up to G1"1/4 orifice 30)
- Version with slow closing diaphragm
- Version for vacuum applications (air/gas)
- Version for use with oxygen (up to G1")

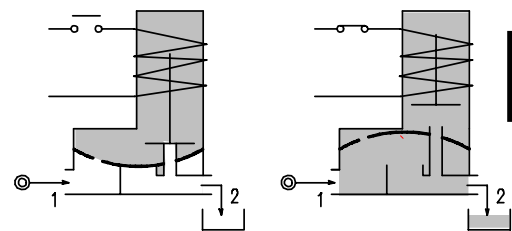
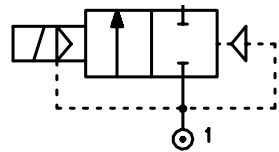

**4**

Certified versions:



CODE ① ②	Connection G ISO 228	Orifice mm	KV m³/h	Differential pressure bar			Nominal power			Coil		Seal ①	Temp. range °C
				Min	Max		AC Inrush	VA Holding	DC Watt	Series	Width		
					AC	DC							
E107B.....10///.....	1/4"	10	1.5	0.15	15	15	12	8	6.5	3	22	NBR=B	-10 +90
E107C.....10///.....	3/8"	10	1.7	0.15	15	15	12	8	6.5	3	22		
E107C.....12///.....	3/8"	12	2.2	0.15	15	15	12	8	6.5	3	22		
E107D.....12///.....	1/2"	12	2.5	0.15	15	15	12	8	6.5	3	22	EPDM=E	<+140
E107E.....18///.....	3/4"	18	5.5	0.15	13	13	12	8	6.5	3	22		
E107F.....25///.....	1"	24	10.2	0.15	10	10	12	8	6.5	3	22		
E107G.....30///.....	1"1/4	30	15	0.15	10	10	12	8	6.5	3	22	FPM=V	-10 +130
E107G.....37///.....	1"1/4	37	18	0.15	10	10	20	15	10	2	30		
E107H.....37///.....	1"1/2	37	21	0.15	10	10	20	15	10	2	30		
E107I.....50///.....	2"	50	36	0.15	10	10	20	15	10	2	30	NBR=B	-10 +90
③E107MB75///.....	2"1/2	75	75	0.3	10	10	20	15	10	2	30		
③E107RB75///.....	3"	75	84	0.3	10	10	20	15	10	2	30		

- ① Seal
  - ② Coil
  - ③ NBR seals – Only for neutral liquid fluid
- Example: E107DB12///301 NBR seal  
Coil 24V DC

\* REMARK: The maximum allowable pressure PS for steam is 2,5bar (gauge pressure)

COILS	Alternating Current ~50/60Hz Volt							Direct Current Volt			Electrical connection	Connectors
	12	24	48	110	220 230	240	380	12	24	48		
Series 3 Width 22 Code ②	30A	30B	30C	30D	30E	30F	30G	300	301	302	DIN 46244	PG9 code 10348000
Series 2 Width 30 Code ②	20A	20B	20C	20D	20E	20F	20G	200	201	202	DIN 43650A	PG9 code 10349000

**DESCRIPTION**  
 Class F insulation  
 Voltage tolerance  
 AC +15% -10%  
 DC ± 10%  
 Protection class  
 IP65 with connector fitted  
 IP00 without connector  
 Continuous service ED100%

**OPTIONS**  
 Class H insulation  
 Cable attached  
 Special coil powers  
 Special coil voltages

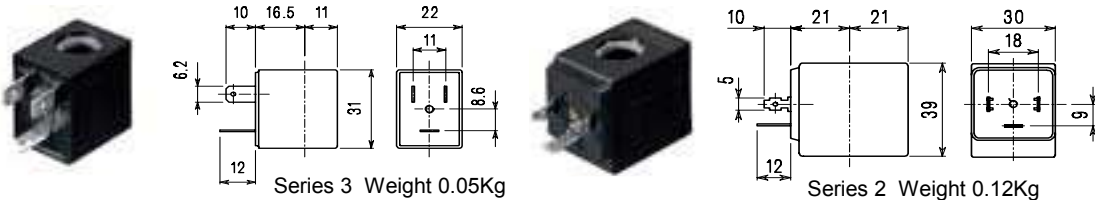

### SPARE PARTS LIST

1. Coil fixing nut
2. Coil
3. Plunger
4. Armature tube with core
5. Diaphragm assembly
6. Speed control valve
7. Water hammering reducer  
Ø0.8-Ø1-Ø1.2

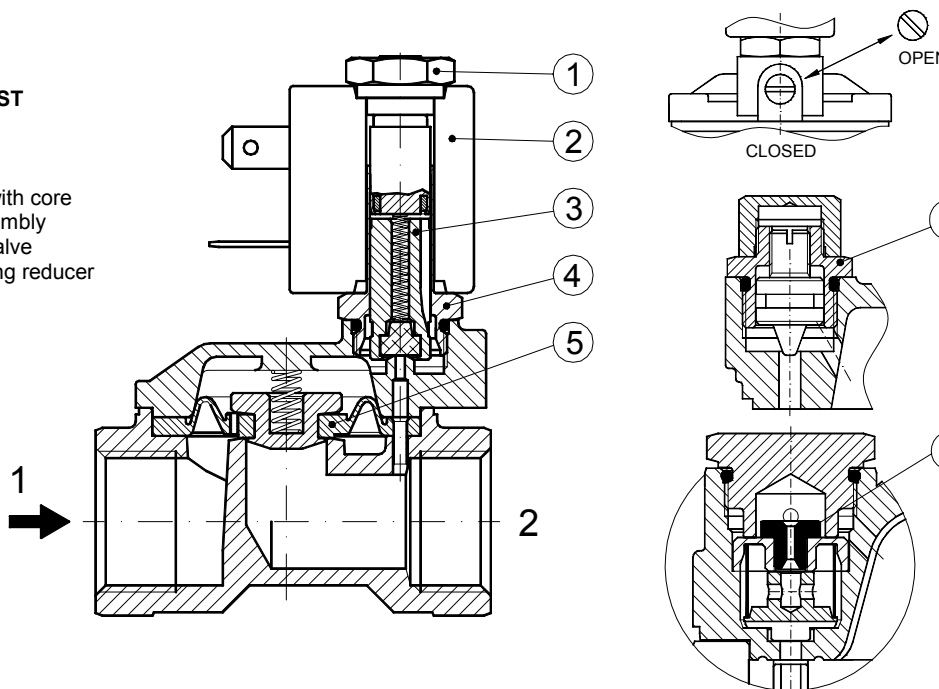

### OVERALL DIMENSION

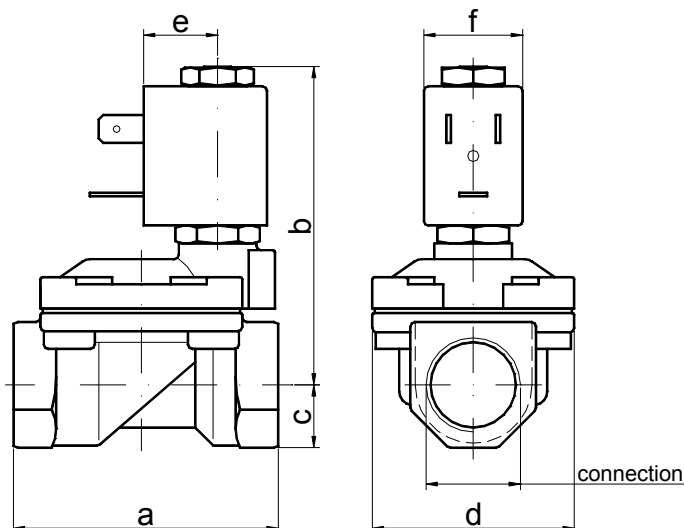

CONNECTION	a	b	c	d	e	f	Weight Kg
G1/4" Ø10	49	65	11	32	16	22	0.25
G3/8" Ø10	49	65	11	32	16	22	0.25
G3/8" Ø12	59	70	14	45	16	22	0.45
G1/2"	59	70	14	45	16	22	0.45
G3/4"	79	74	18	55	16	22	0.66
G1"	96	85	20	72	16	22	1.05
G1 1/4" Ø30	119	92	25	85	16	22	1.80
G1 1/4"	142	107	28	102	21	30	2.95
G1 1/2"	142	107	28	102	21	30	2.74
G2"	158	117	35	119	21	30	4.50
G2 1/2"	226	134	51	169	21	30	10
G3"	226	134	51	169	21	30	9.65