

COILS	Alternating Current ~50/60Hz Volt				Direct current Volt			Electrical connection
	24	48	110	220 230	12	24	48	
Series A6 Code ①	A6B	A6C	A6D	A6E	A60	A61	A62	1/2" NPT

DESCRIPTION
 Voltage tolerance
 AC +15% -10%
 DC ± 10%
 Protection class IP66

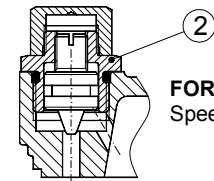

FOR G1"1/4-1"1/2-2"
 Speed control valve

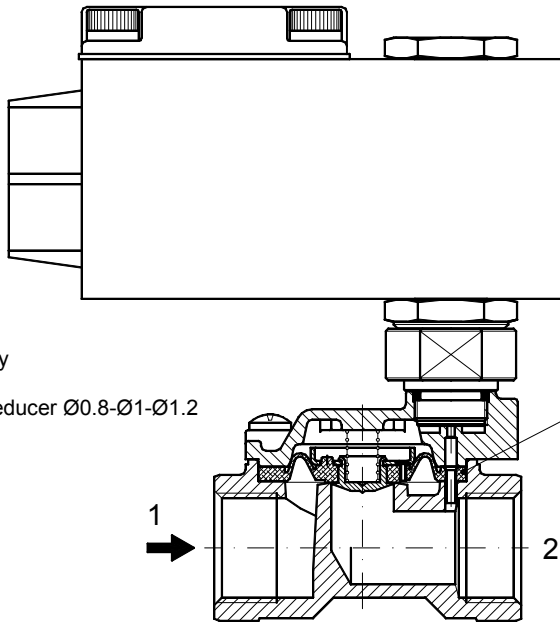
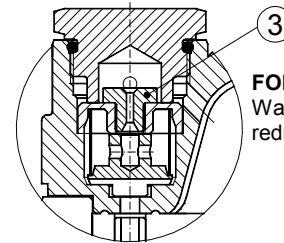

FOR G2"1/2-3"
 Water hammering
 reducer Ø0.8-Ø1-Ø1.2

SPARE PARTS LIST

1. Diaphragm assembly
2. Speed control valve
3. Water hammering reducer Ø0.8-Ø1-Ø1.2

OVERALL DIMENSION

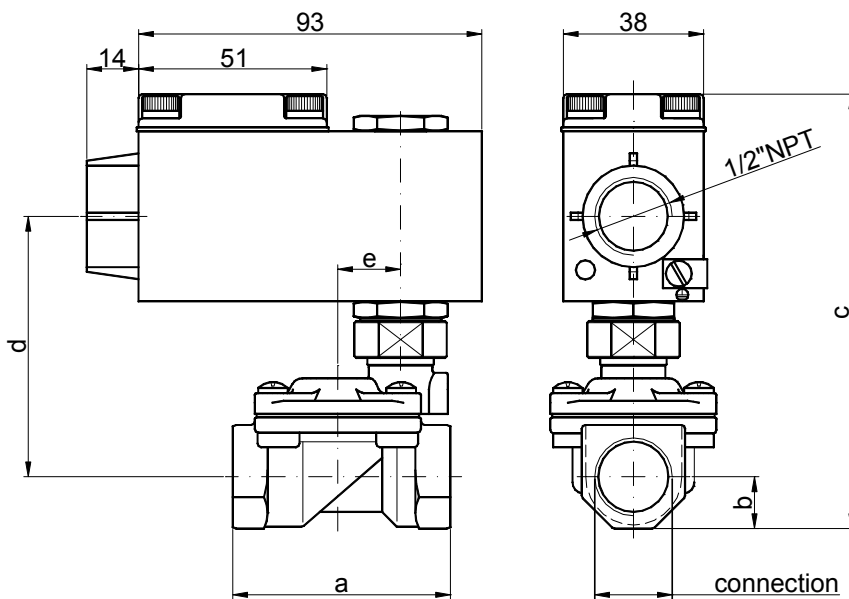

CONNECTION	a	b	c	d	e	Weight Kg
G1/4" Ø10	49	11	110	66	16	0.72
G3/8" Ø10	49	11	110	66	16	0.72
G3/8" Ø12	59	14	118	70	17	0.92
G1/2"	59	14	118	70	17	0.92
G3/4"	79	18	127	75.5	22.2	1.12
G1"	96	20	141	88	30.2	1.50
G1"1/4 Ø30	119	25	150	91	36	2.27
G1"1/4	142	28	147	86	43	3.33
G1"1/2	142	28	147	86	43	3.12
G2"	158	35	168	95	48	4.72
G2"1/2	226	51	197	112	69.2	10.40
G3"	226	51	197	112	69.2	10